

Purged/Packed Inlet EPC Pneumatic Module **(HP part no. G1543-60500)**

Description	HP Part No.	Qty.
1. 1/8" SwageLok Male Connector SAE, Brass	G1543-80030	1
2. Inlet Fitting	G1543-20510	1
3. Screw, M4 x 45 mm, Torx T20	0515-2484	1
4. EPC Valve, Replacement kit	G1530-60610	1
5. O-rings, HPM8 (Order HP Part No. 5180-4181, 12/pkg)		2
6. Screw, M3 x 20 mm, Torx T10	0515-1319	4
7. O-rings, .239 id (Order HP Part No. 5180-4182, 12/pkg)		1

For diagram of screw and O-ring placement in pneumatic modules see figure 1310-7 on page 15 of this section.

Purged/Packed Inlet EPC Pneumatic Module

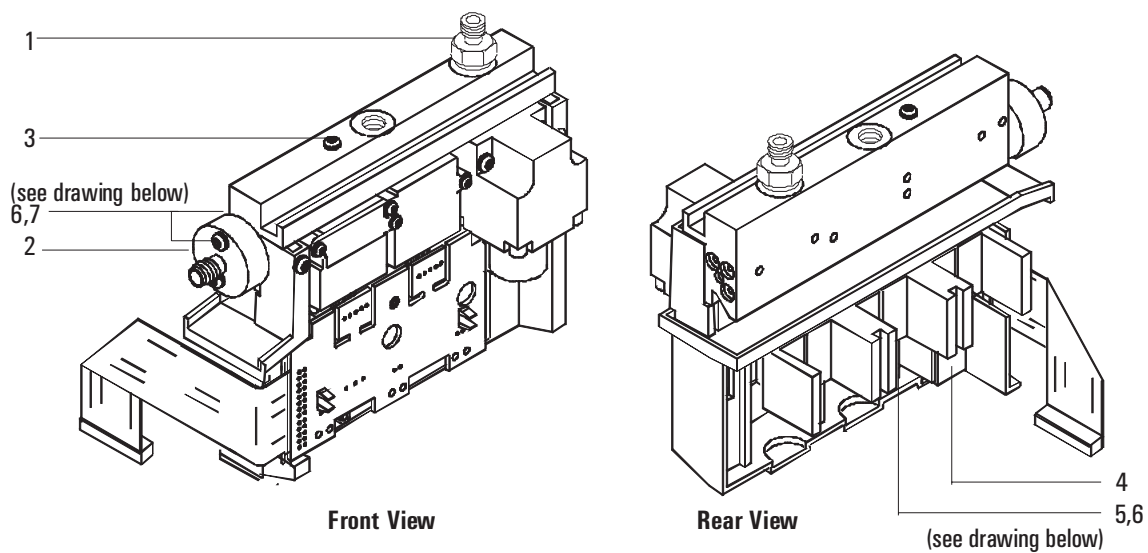

Figure 1310-6 Purged/Packed Inlet EPC Pneumatic Module

Caution

Aluminum bracket removed for clarity, **DO NOT** completely remove the bracket during valve replacement.

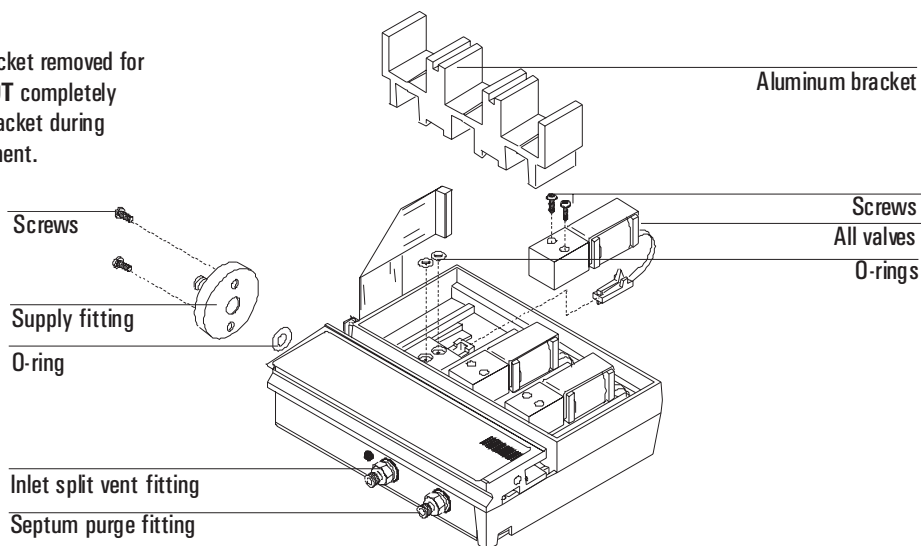

Figure 1310-7 Serviceable Parts Drawing for any EPC Pneumatic Module